



FEATURES:

- OIL-FREE
- 59 dB @ 25 FT.
- 10.5 CFM @ 100 PSI
- 3.0 HORSEPOWER (running)
- 60 GALLON ASME TANK
- HEAVY DUTY PRESSURE SWITCH
- 120 VOLT REQUIRES 20 AMP RECEPTACLE & BREAKER
- LOW RPM
- LIFE EXPECTANCY UP TO 10X LONGER THAN MOST OIL-FREE AIR COMPRESSORS

**120
VOLT**



Requires 120v
20 Amp
Receptacle

SPECIFICATIONS:

- MODEL: EA-10000
- CFM @ 100 PSI: 10.5
- TANK CAPACITY: 60 GALLON
- DIMENSIONS: 27" L X 24" W X 65" H
- HORSEPOWER: 3.0 (running)
- WEIGHT: 285 LBS.

EAGLE SILENT SERIES

**DESIGNED
& BUILT**

STRONG

**FOR
PROFESSIONALS**

ALL STEEL



**CONSTRUCTION
PROTECTS
CRITICAL
COMPONENTS
FROM JOBSITE**



MORE THAN 80% QUIETER

(THAN TRADITIONAL
AIR COMPRESSORS)



**ONLY 59dB
@ 25'**

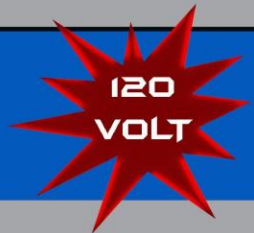

UNMATCHED FEATURES & SPECIFICATIONS

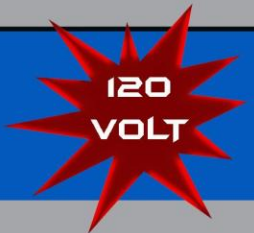

- ▶ **DUAL TWIN CYLINDER PUMP**
- ▶ **HEAVY DUTY INDUCTION MOTORS**
- ▶ **LOW 1720 RPM**
- ▶ **MAINTENANCE FREE**
- ▶ **OIL FREE**

- ▶ **3.0 HP**
- ▶ **60 GALLON ASME**
- ▶ **10.5 CFM @ 100 PSI**
- ▶ **59 dB @ 25'**
- ▶ **125 PSI MAX**



EA-10000



DUAL QUICK CONNECTS INCLUDED



120 VOLT POWER CORD INCLUDED



REGULATOR INCLUDED



DUAL GAUGES INCLUDED

(NONE of the above items are included with other 60 gallon air compressors)

FULL COLOR FEATURES LABEL ON TANK

SILENT TECHNOLOGY ONLY 59 dB @ 25'

120 VOLT PLUG & PLAY

3.0 HORSE POWER **120 VOLT** **60 GALLON TANK**

10.5 CFM @ 100 PSI

EAGLE SILENT SERIES

Requires 120v 20 Amp Receptacle

Scan me to watch the video and hear just how quiet I am! You won't believe your ears!!!

F • OIL-FREE
E • 59 DB @ 25 FT.
A • 10.5 CFM @ 100 PSI
T • 3.0 HORSEPOWER
U • 60 GALLON ASME TANK
R • QUIETEST PROFESSIONAL AIR COMPRESSOR IN IT'S CLASS
E • HEAVY DUTY PRESSURE SWITCH
S • 120 VOLT REQUIRES 20 AMP RECEPTACLE
 • LIFE EXPECTANCY UP TO 10X MORE THAN MOST OIL-FREE AIR COMPRESSORS
 • LOW 1750 RPM

ONSITE SERVICE 1-800-551-2406
www.eaglecompressor.com

LOW RPM'S = LONGER LIFE

OIL-FREE



EA-10000



DUAL QUICK CONNECTS INCLUDED



120 VOLT POWER CORD INCLUDED



REGULATOR INCLUDED



DUAL GAUGES INCLUDED

(NONE of the above items are included with other 60 gallon air compressors)

FULL COLOR FEATURES LABEL ON TANK

SILENT TECHNOLOGY ONLY 59 dB @ 25'

120 VOLT PLUG & PLAY

3.0 HORSE POWER **120 VOLT** **60 GALLON TANK**

10.5 CFM @ 100 PSI

EAGLE SILENT SERIES

Requires 120v 20 Amp Receptacle

Scan me to watch the video and hear just how quiet I am! You won't believe your ears!!!

F • OIL-FREE
E • 59 DB @ 25 FT.
A • 10.5 CFM @ 100 PSI
T • 3.0 HORSEPOWER
U • 60 GALLON ASME TANK
R • QUIETEST PROFESSIONAL AIR COMPRESSOR IN IT'S CLASS
E • HEAVY DUTY PRESSURE SWITCH
S • 120 VOLT REQUIRES 20 AMP RECEPTACLE
 • LIFE EXPECTANCY UP TO 10X MORE THAN MOST OIL-FREE AIR COMPRESSORS
 • LOW 1750 RPM

ONSITE SERVICE 1-800-551-2406
www.eaglecompressor.com

LOW RPM'S = LONGER LIFE

OIL-FREE



EA-10000



**The Only 120 volt
Plug & Play
60 Gallon
Compressor
In The Market!!!**



***Requires "T" Style
20 Amp 120 Volt
Receptacle**

PATENTED TECHNOLOGY

Multiple



Patents

LOW MAINTENANCE

**Eagle
technology
outlasts other
oil-free designs
up to 10X**

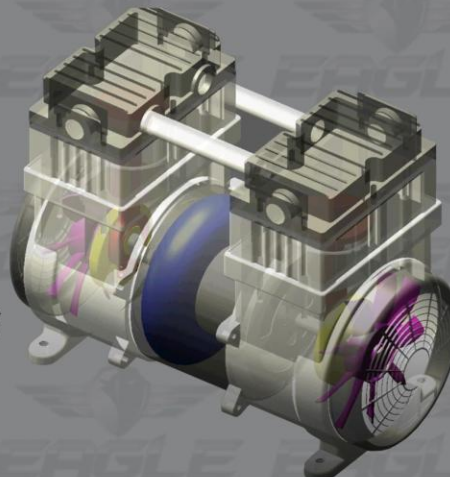































**Oil-Free
Pump/Motor
Operation
Means Less
Maintenance**

EA-10000 DIMENSIONS 27" L x 24" W x 65" H



Air Tool Usage Guide

 Inflation 	 Brad Nailer 	 Stapler 	 Framing/Roofing 	 1/2" & 3/4" Impact Wrench 
 Heavy-Duty 1" Impact Wrench 	 Air Ratchet 	 Air Hammer 	 Cut Off Tool 	 Drill/Impact Driver 
 Sanding 	 Grinder 	 Painting 	 HVLV Painting 	 Grease Gun 

 = Continuous
  = Intermittent
  = Not Recommended

Model #: EA-10000



EA-10000



*Every EA-10000 is covered by a **ONE YEAR Limited Warranty***



ON SITE SERVICE

We come to you!



PROVEN PERFORMANCE



**OVER 45
YEARS OF
MANUFACTURING
QUALITY
AIR COMPRESSORS**

**QUALITY YOU CAN RELY ON -
A NAME YOU CAN TRUST**



**PROUDLY ASSEMBLED IN THE
UNITED STATES OF AMERICA**

